

SJ30 Series Multi Axis Joystick

Product Features

- Spring return, single-axis or dual-axis operated.
- Cross direction or arbitrary direction operated optional.
- Potentiometer or hall effect angle detection, long life.
- Large current microswitch optional (10A@30Vdc).
- Various output optional.
- Various handle optional.

Application

Typical apply on rotary drilling rigs, aerial fire trucks, Cranes shield machine and other electrical and electro-hydraulic control system.



Technical Information

Electrical data

Potentiometer

Power supply	<36Vdc
Center angle Power	5K Ω , 10K Ω
Center angle	$\pm 3^\circ$
dissipation	0.2W

Hall

Power supply	5 \pm 0.5Vdc
Supply voltage Supply current	<11 mA (Single axis), <22mA (Dual-axis)
Maximum allowable overload voltage	20Vdc
Reverse maximum allowable voltage	-10Vdc
Output linearity tolerance	< \pm 0.2V

With electronic amplifier

Power supply	18~36Vdc (U 21~U 24)
Current consumption	<20mA
Output current (max)	10mA With standard voltage output

2-wire system current

Power supply	9~36Vdc (I21~I22)
--------------	-------------------

4-wire system current

Power supply	9~36Vdc (I41~I42)
--------------	-------------------

Microswitch

Load capacity	1 0A@30Vdc (Resistance load)
Expecting life	>30 million cycles (Mechanical) >200 thousand cycles (Electrical)
Insulation resistance	>100M Ω 500Vdc Insulating-resistance meter
Breakout angle	$\pm 3^\circ$ ~ $\pm 5^\circ$

Mechanical features

Travel angle	$\pm 25^\circ$
Operating type	Spring return
Breakout force	5N
Operating force(max)	30N
Maximum allowable force	>300N
Expecting life	>2million cycles (Potentiometer) >5 million cycles (Hall)
Weight	460g (Without handle)

Environmental data

Operating Temperature	-30 $^\circ$ C~ +70 $^\circ$ C
Storage Temperature	-40 $^\circ$ C~+85 $^\circ$ C
Protection level	IP65 (Above the flange)

Product Configuration

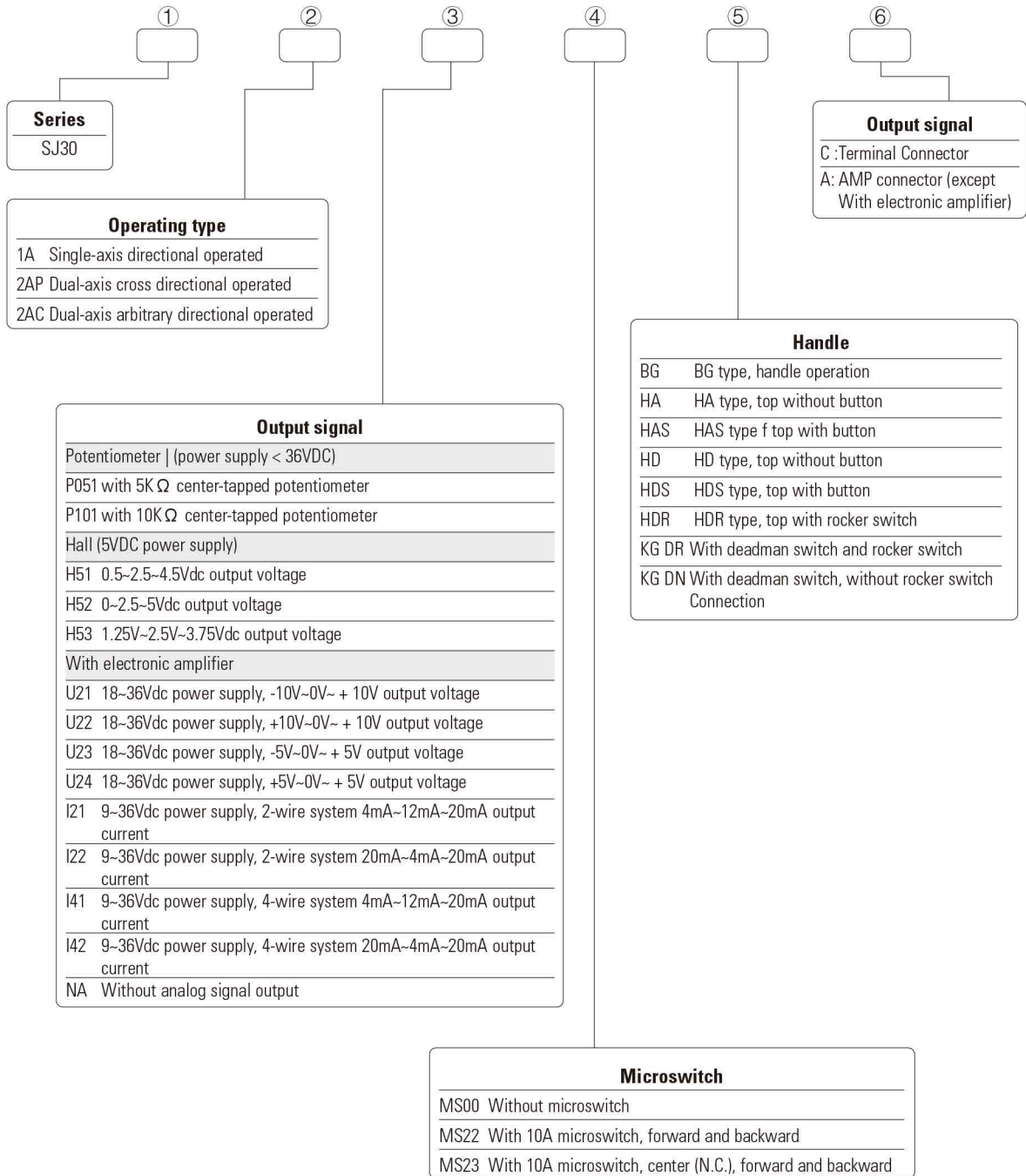

Dimensions

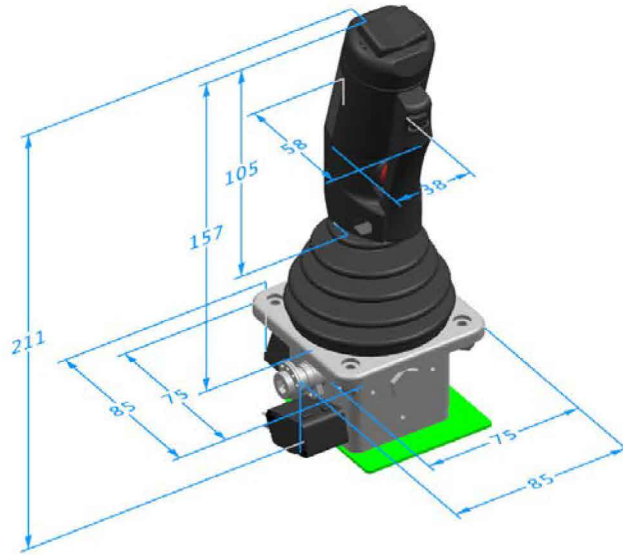

Product Installation

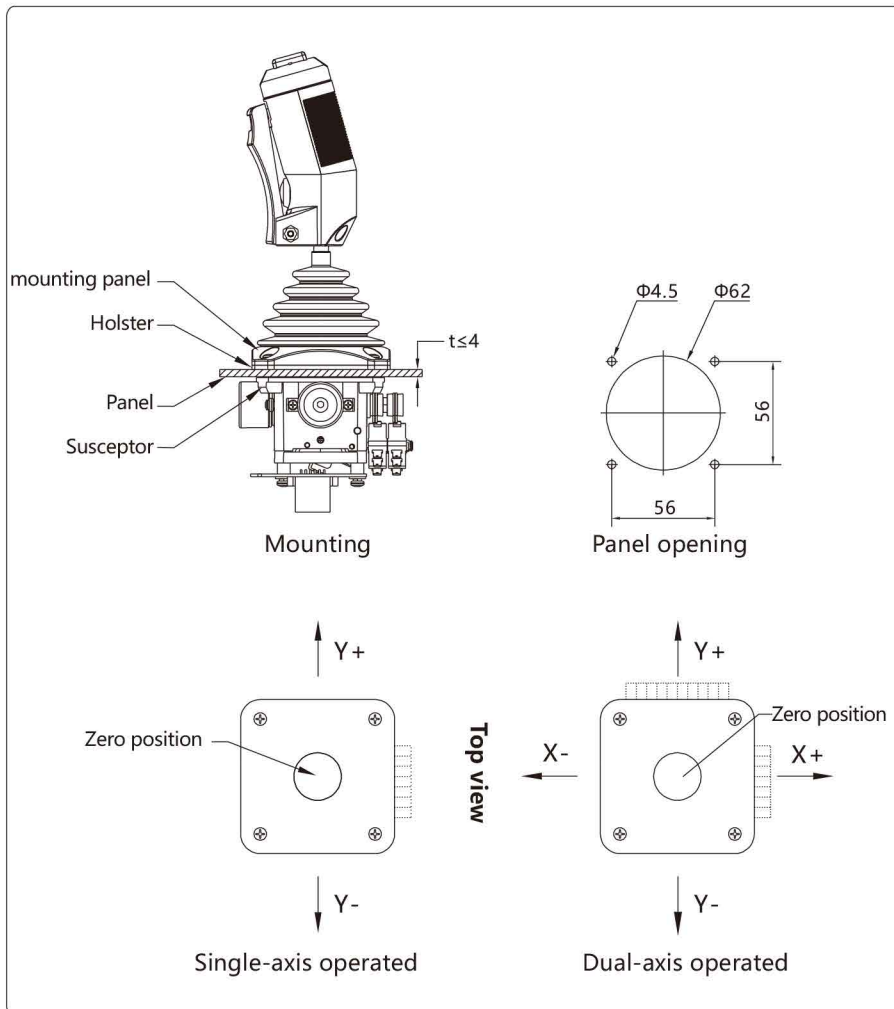

Electrical Connections

AMP connector

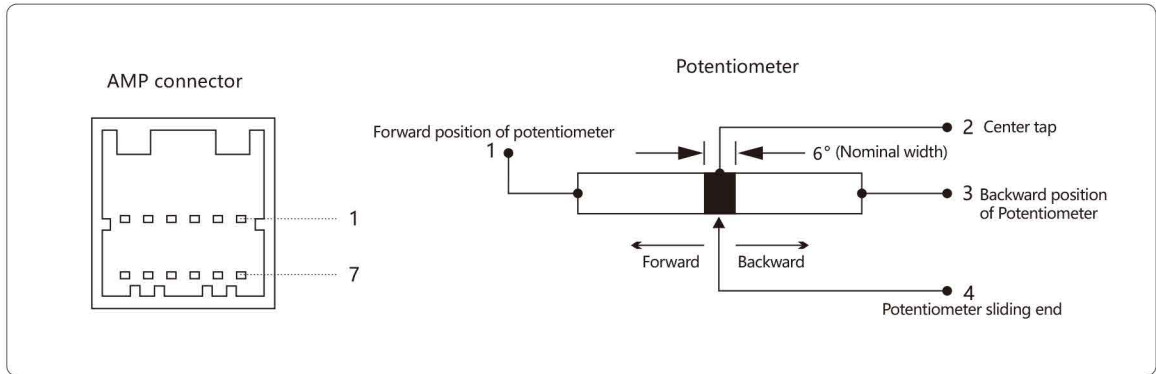

Pin	Potentiometer	Hall
1	Potentiometer forward terminal	+5Vdc
2	Potentiometer center tap	NA
3	Single direction(N/A)	0V
4	Potentiometer backward terminal	Output
5	Potentiometer wiper	Forward Directional switch (N.O.)
6	Forward Directional switch (N.O.)	Start position switch of single direction (N.O.)
7	Start position switch of single direction (N.O.)	Forward switch common terminal
8	Forward switch common terminal	Common terminal of start position
9	Common terminal of start position	Backward directional switch (N.O.)
10	Backward directional switch (N.O.)	Single direction(N/A)
11	Single direction(N/A)	Backward directional common terminal
12	Backward directional common terminal	Single direction(N/A)
	Single direction(N/A)	Rocker left direction (N.O.)
	Rocker left direction (N.O.)	Handle of top switch common terminal
	Handle of top switch common terminal	Rocker right direction (N.O.)
	Rocker right direction (N.O.)	Deadman switch
	Deadman switch	

Connector

